

1-877-903-7246

# IIIIITRENCHIFY

www.trenchify.com

<p><b>Number</b></p> <p><b>100-DIS-C-PS</b></p>	<p><b>Series</b></p> <p><b>CPS100</b></p> <p>C Class Ductile Iron Slotted Grate</p> <p>Pro Plus 100</p>
---	---

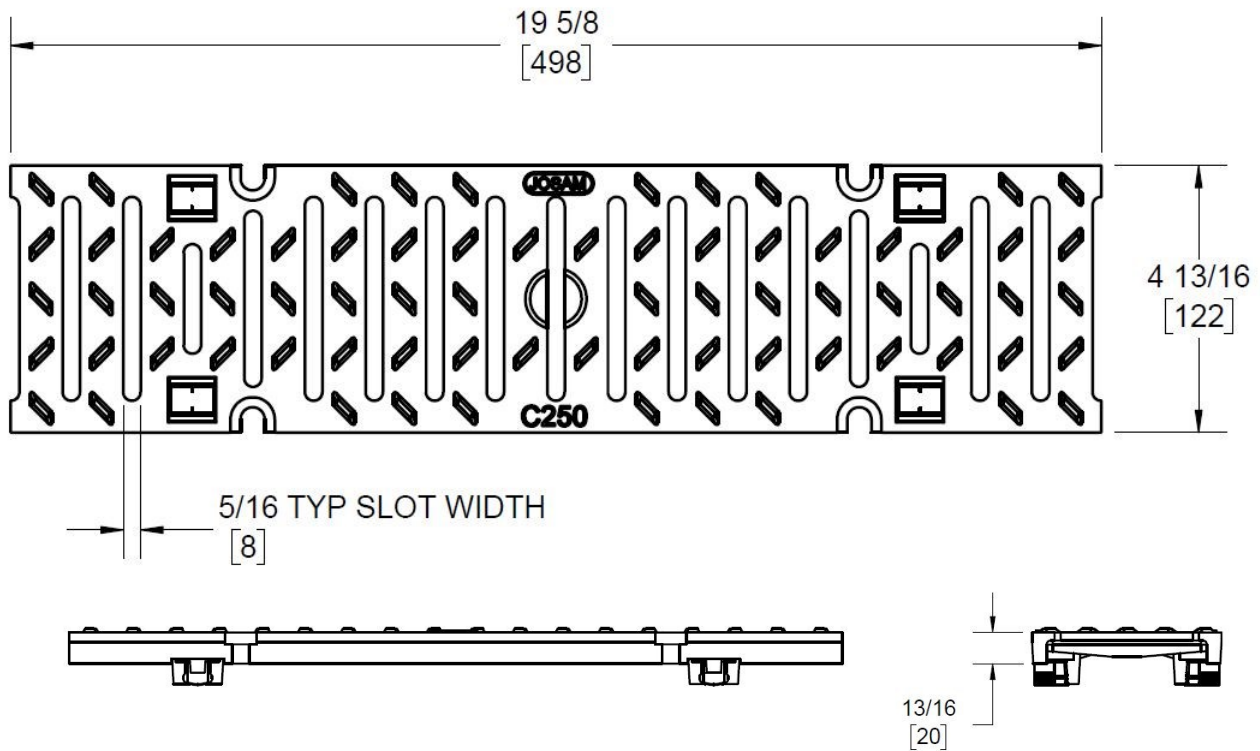

**Manufacturer**



**Specification**

JOSAM 100-DIS-C-PS EPOXY-COATED, DUCTILE IRON SLOTTED GRATE WITH PRO-SNAP™ SECUREMENT. DESIGNED TO FIT PROPLUS™ 100 SIZE CHANNEL. MEETS CLASS C LOADING REQUIREMENTS. MEETS ADA AND HEELPROOF SLOT REQUIREMENTS, SUPPLIED BY TRENCHIFY.

DISCLAIMER - The customer and the customer's architects, engineers, consultants, and other professionals are completely responsible for the selection installation and maintenance of any product purchased from Trenchify and/or its manufacturers. TRENCHIFY MAKES NO WARRANTY, EXPRESS OR IMPLIED, AS TO THE SUITABILITY, DESIGN, MERCHANTABILITY, OR FITNESS OF THE PRODUCT FOR CUSTOMERS APPLICATION. The drawing and information provided remain the property and copyright of the manufacturer listed. The manufacturer reserves the right to modify specification without notice.